

FILLING & EMPTYING / TRANSFER & MIXING /
CAN OPEN & CRUSH

ADDITIONAL EQUIPMENT



DC NORRIS
NORTH AMERICA

ADDITIONAL
**INDUSTRIAL FOOD PROCESSING
EQUIPMENT**

PUMP FILL
CAN CRUSHER
CAN OPENERS
TRANSFER & MIXING VESSELS



DC NORRIS
NORTH AMERICA

PUMP FILL STATION

DC Norris North America offers two different ways to fill product for cook chill purposes. DC Norris pump fill station is available in volumetric piston pump, lobe pump or sine pump to meet individual product and accuracy needs. A load cell version is also available for clients needing to offer bagged product for retail sales. As an alternative for a more automated filling solution DC Norris can offer a vertical form fill and seal machine suitable for hot or cold fill. This machine is equipped with a volumetric piston type pump for accurate fill weights.

The DC Norris pump fill station and vertical form fill and seal machines are also available for filling product outside of the cook chill process.

Part of the DCN Cook-Chill Process; a stand-alone unit for the accurate batching of product into pouches ready for cooking or cooling. This state of the art pump fill station is fully mobile and equipped with a special food grade pump designed to handle high and low viscosity products without damaging sensitive particulates.



SUITED FOR

- Steam Purge
- Load Cell for greater accuracy
- CIP

- Temperature cut-out to prevent cold filling of bags
- Clipping head with 'no-clip' alarm
- Pumps solids (1 1/4") with no product damage
- Positive rotary pump
- CIP incorporation (optional)
- 390 model available with sine pump for thick products such as mash potato and porridge
- Manufactured in the UK, UL compliant

PUMP FILL STATION FEATURES

- All stainless steel construction
- PLC control
- Stored pouch/product volumes
- Push button "self teach" version

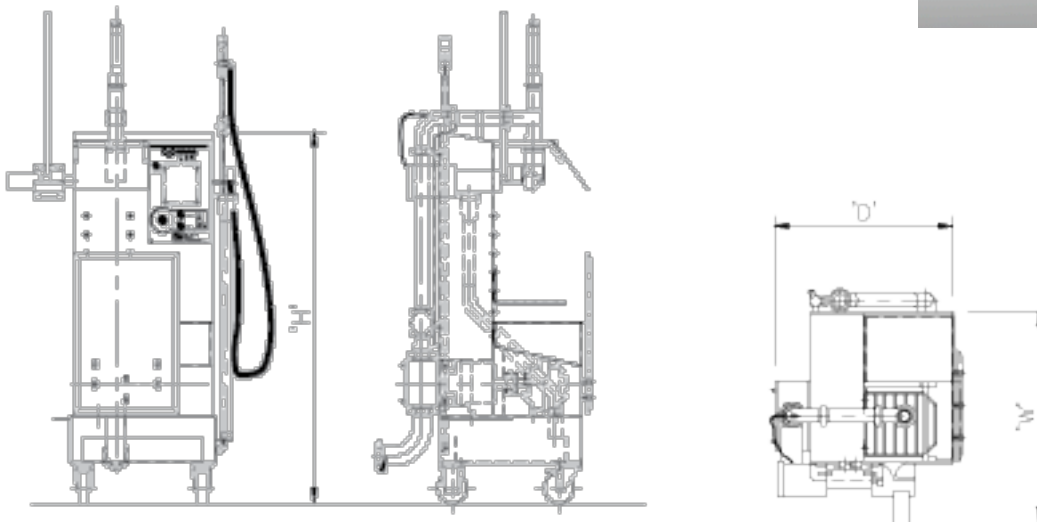

	REQUIREMENT	CONNECTION
Air	1USG @85 PSI	.5" BSP
Voltage	230VAC-16A	.75"
Product	GRAVITY FEED	3" RJT/IDF

HEIGHT	WIDTH	LENGTH	WEIGHT (LBS)
76.5"	32.5"	28.75"	550

INDUSTRIAL CAN CRUSHER

The DC Norris Model 990 can crusher is a heavy duty table top machine capable of crushing the majority of domestic and industrial cans to approximately 20% of the original size. The operation is as simple as opening the lid, dropping in the can, closing the lid and the can is crushed and ejected out of the exit chute. Taking just a few seconds to complete the action. Savings can be achieved, by increasing space in your dumpster or recycling bins by as much as 80%!



MODEL 990 CAN CRUSHER FEATURES CUSTOM OPTIONS

- Manufactured in stainless steel and food approved plastics
- Capable throughput of 200-300 cans per hour
- Maximum can size 6.3 diameter x 10.3 inches high
- Compressed air required for simple operation
- Safety features are built into the machine rendering it inoperative should the lid be opened
- Easy cleaning
- Stand Alone Support Table
- Can Crusher Stand
- Customers also have an option to upgrade to a semi-automatic mid-range line, ideal for larger batches and open and crush #10 cans at a rate of up to 800 cans per hour

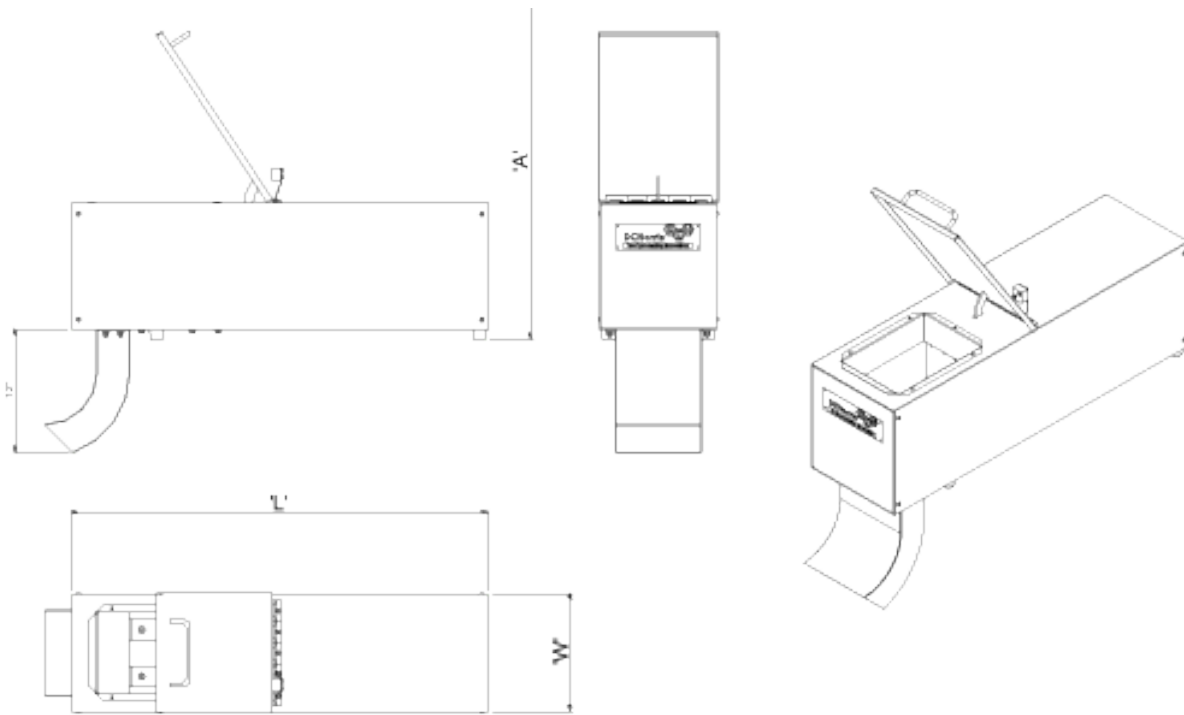

	PRESSURE	SIZE
COMPRESSED AIR	85cfm @ 90 ps	.5" BSP

DIM A	DIM W	DIM L
32.6"	10.9"	38.8"

TRANSFER/HOLDING VESSEL

DC Norris transfer vessels are ideal for the vacuum, pressure filling and transfer of hot or cold liquid product. The vessel is available in various sizes up to 250 gallons and can be mounted on two fixed and two swivel castors, allowing the tank to also serve as a mobile holding vessel. Made from 304-grade stainless steel, vessels can be custom made to your requirements. Loading under vacuum and discharge by over-pressure removes the need for expensive pumps and minimises shear damage potential.



TRANSFER VESSEL FEATURES

- Insulated / jacketed
- Agitated or non-agitated models available
- Hinged lid
- Hygienic butterfly valve outlet
- Mobile (with nylon castors) Optional
- Stainless steel grade 316 / 304
- Standard sizes 80 gallon to 250gallon (custom sizes available)
- Designed to PD5500 & ASME

TECHNICAL SPECIFICATIONS

- Pressure Options:
 - Atmospheric
 - Full Vacuum
 - Pressure up to 15psi
- Outlet Size - 3" diameter
- Agitation by compressed air drive or electric motor (Optional)

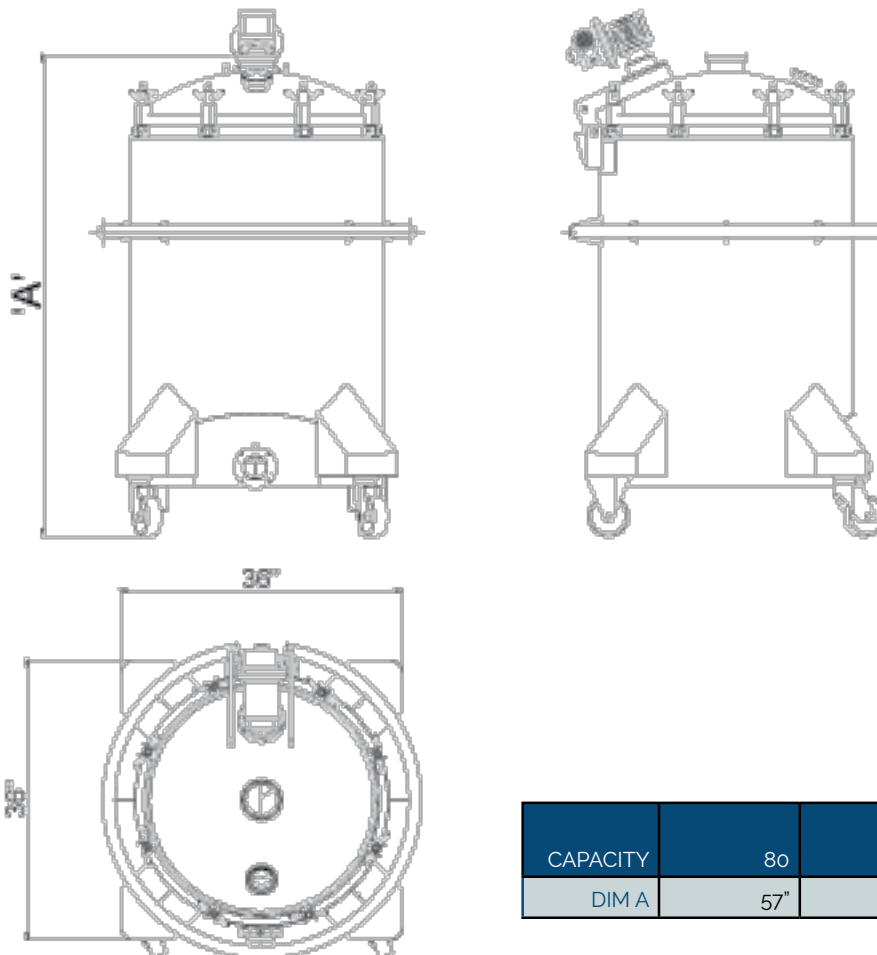

CAPACITY	80	100	125
DIM A	57"	58"	75"

SEMI-AUTO CAN OPENER (MODEL 175)

PLC controlled mid-range semi-automatic can-opener is ideal for large batches with a throughput of up to 800 cans per hour. The stainless steel design uses the crown punch opening system and also has the additional benefit of an automatic can crusher.

MODEL 175 FEATURES

- Removes lid in one cut
- Leaves no metal chips
- Can reject system
- Fully enclosed blade
- In-feed conveyor
- Twist box
- Manufactured to USDA, FDA, ASME, UL and NSF standards

CUSTOM OPTIONS

- Wash/dry tunnel
- Product/liquid separation chute
- Product removal system
- Can wash/rinse systems
- Lid rinsing device
- Outfeed conveyors

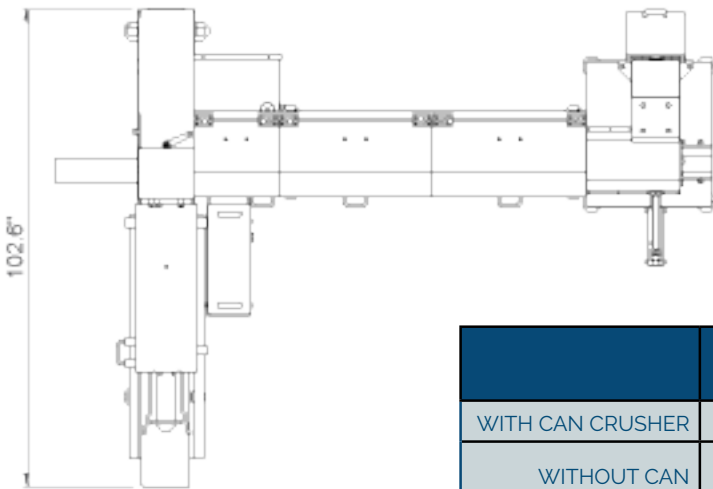
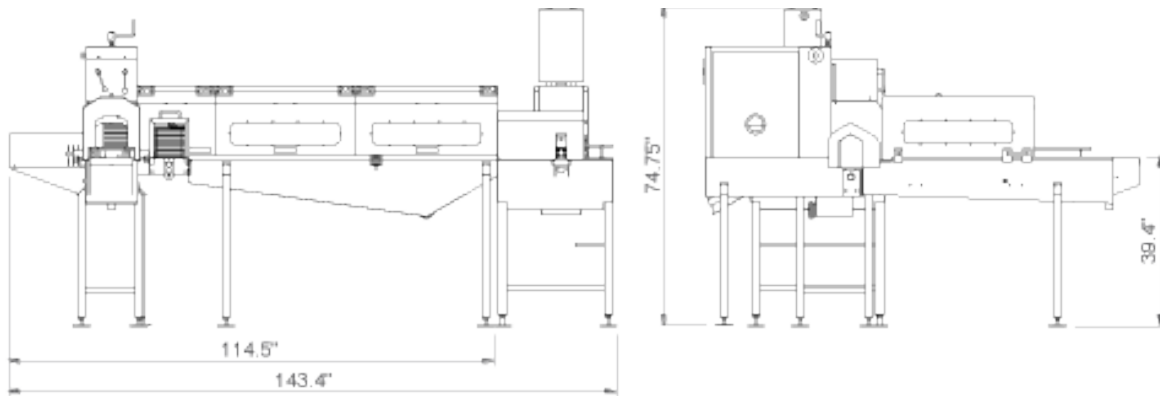

	REQUIREMENT	CONNECTION
AIR WITHOUT CRUSHER	8.83 cfm @ 87.02psi	1"
AIR WITH CRUSHER	42.38 cfm @ 87.02 psi	1"
ELECTRICAL (LOCAL CONNECTION)	240V single phase 60Hz	

	HEIGHT	DEPTH	LENGTH	WEIGHT (LBS)
WITH CAN CRUSHER	74.75"	102.6"	143.4"	1212.5
WITHOUT CAN CRUSHER	71.5"	102.6"	114.5"	881.8

MANUAL CAN OPENER (MODEL 160)

The model 160 pneumatically operated can-opener is ideal for small quantities and is adaptable for a range of can sizes and shapes.

With a capable throughput of 200-300 cans an hour, removing the lid in one easy cut, the can-opener can greatly improve production times.



MODEL 160 FEATURES

- Adjustable for different sized cans - 2.4 to 9.1 inch diameter
- Manufactured with hygienic glass bead-blasted stainless steel
- Two handed start
- Fully enclosed blade
- No metal chips
- Interchangeable heads
- Height block kit included
- Quick release heads for easy cleaning
- Manufactured to USDA, FDA, ASME, UL and NSF standards

CUSTOM OPTIONS

- Support stand
- Infeed table
- Can rinse/air blast water removal unit
- Product chute
- Drop-in mesh
- Can crushing system
- Magnetic lid removal system
- Vibratory conveyor

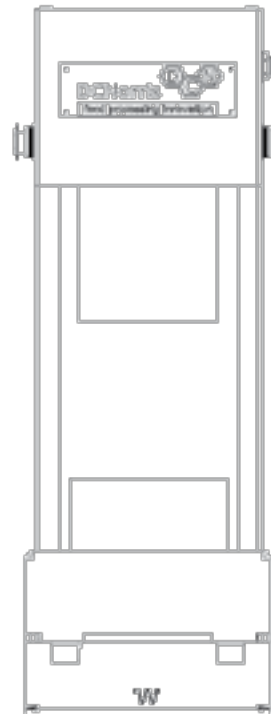
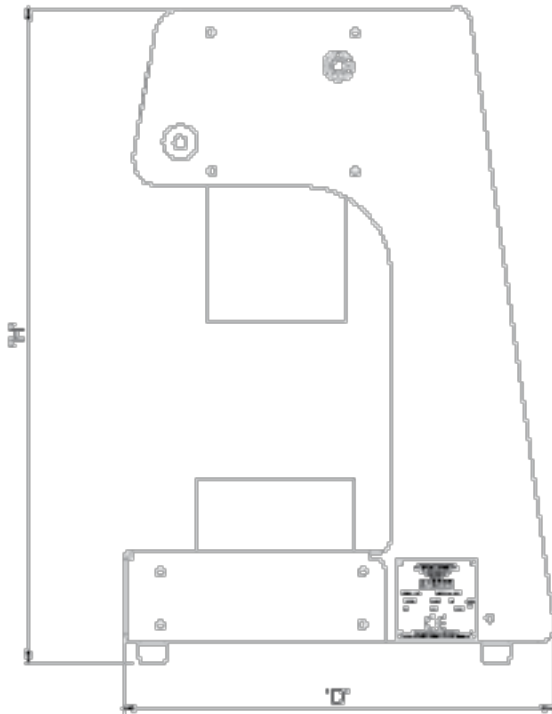

HEIGHT	WIDTH	DEPTH	WEIGHT (LBS)
29.3"	11"	19"	79

	PRESSURE	CONNECTION
AIR	87 PSI	.5" BSP

WE'RE HERE TO HELP YOU LEAD THE EVOLVING NORTH AMERICAN FOOD MARKET

The processing equipment manufactured by DC Norris leads the global food production industry. So too, do our teams. Our commitment to partnership with our clients is what truly drives global food cultures forward. Together, we innovate to feed the world the best foods possible and to make continual strides in convenience and accessibility by improving efficiency, lowering cost, and minimizing environmental impact.

DC Norris North America

WWW.DCNORRISNA.COM

231.935.1519
mail@dcnorrisna.com



DC NORRIS
NORTH AMERICA