

DA Cooler

- ◆ Cooling jacket with 45 psi operating pressure and special dimpled pattern to give optimum cooling performance
- ◆ Vessel is capable of taking a vacuum to allow filling of product without the need for transfer pumps
- ◆ Product can be discharged under pressure negating the need for expensive pumps and additional cleaning
- ◆ Insulated with a conical bottom and stainless steel cladding
- ◆ Vertical product zone with scraping surface type, variable speed agitator fitted with replaceable food approved plastic blades
- ◆ Fixed lid design with manway for incorporating into CIP cleaning systems
- ◆ Can be integrated with DCN kettles, bratt pans and vacuum trolleys
- ◆ Manufactured to USDA, FDA, ASME, UL and NSF standards

CUSTOM FEATURES AVAILABLE

- ⇒ Vacuum Transfer System
- ⇒ Sterile Air Kit
- ⇒ Spray Heads
- ⇒ Cooler Control System
- ⇒ Full diameter, counter balanced, domed top lid for complete access to product zone

Glycol-jacketed cooling vessel designed for the cooling of a wide range of food products including soups, stews, sauces and preserves.

For processes that require large batch cooling in stand-alone vessels, DCN offers an extensive range of static DA Coolers with unique scraped surface agitators.

The large surface area to product ratio allows rapid cooling times without damage to particulates or adverse effect on quality or taste. Product is gently transferred to the coolers using our vacuum transfer system and the cooling cycle is closely monitored to eliminate the risk of thermal shock or separation. Once cooled, product can be transferred into filler hoppers or into DCN transfer vessels by conventional pumps and pipework, or by using air 'over-pressure'.



DC NORRIS
NORTH AMERICA

Batch Sizes: 75 - 200 gallons (custom sizes made to order)

Interior: Standard internal sanitary finish.

Exterior: Semi-deluxe buff finish (or to customers specification)

TECHNICAL DATA

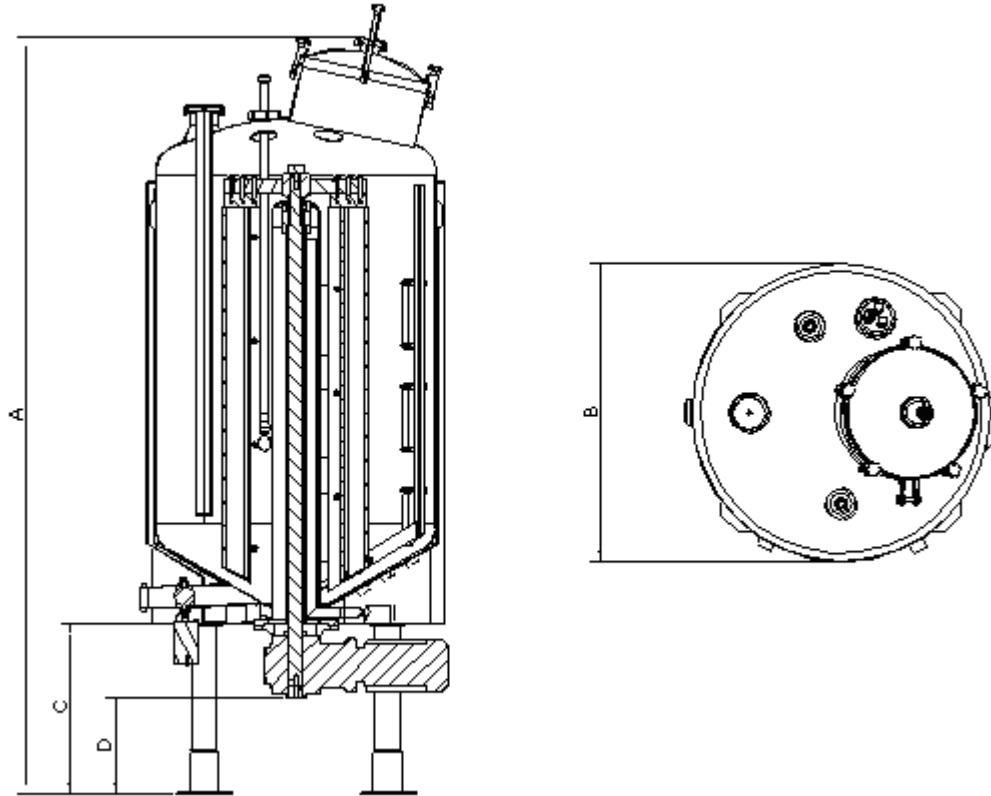

Cooler Size (gallons)	Overall Height (Dim A - inches)	Diameter (Dim B - inches)	Leg Length (Dim C - inches)	Motor to Floor Clearance (Dim D - inches)
75	83.75"	41.75"	23.75"	13.50"
100	88.5"	41.75"	23.75"	13.50"
130	93"	41.75"	23.75"	13.50"
200	105.75"	41.75"	23.75"	13.50"



DC Norris North America LLC

2375 Traversefield Drive
 Traverse City
 MICHIGAN
 49686
 USA

t: (+1) 231. 935. 1519
e: mail@dcnorrisna.com
w: www.dcnorrisna.com



DC NORRIS
 NORTH AMERICA