

# TRANSFER/HOLDING VESSEL

## Features:

- Insulated / jacketed
- Agitated or non-agitated models available
- Hinged lid
- Hygienic butterfly valve outlet
- Mobile (with nylon castors) Optional
- Stainless steel grade 316 / 304
- Standard sizes 80 gallon to 250gallon (custom sizes available)
- Designed to PD5500 & ASME

DCN Transfer Vessels are ideal for the vacuum, pressure filling and transfer of hot or cold liquid product.

The vessel is available in various sizes up to 250 gallons and can be mounted on two fixed and two swivel castors, allowing the tank to also serve as a mobile holding vessel.

Made from 304-grade stainless steel, vessels can be custom made to your requirements.

Loading under vacuum and discharge by over-pressure removes the need for expensive pumps and minimises shear damage potential.



## Technical Specifications:

- Pressure Options:
  - Atmospheric
  - Full Vacuum
  - Pressure up to 15psi
- Outlet Size - 3" diameter
- Agitation by compressed air drive or electric motor (Optional)



**DC NORRIS**  
NORTH AMERICA

# TECHNICAL DATA

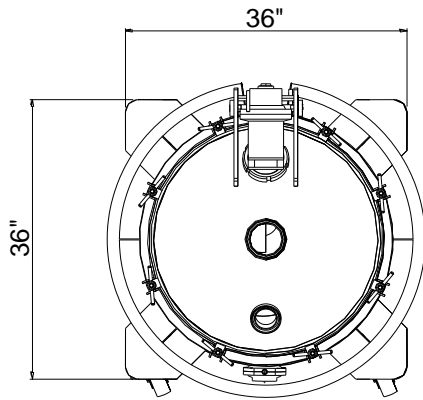
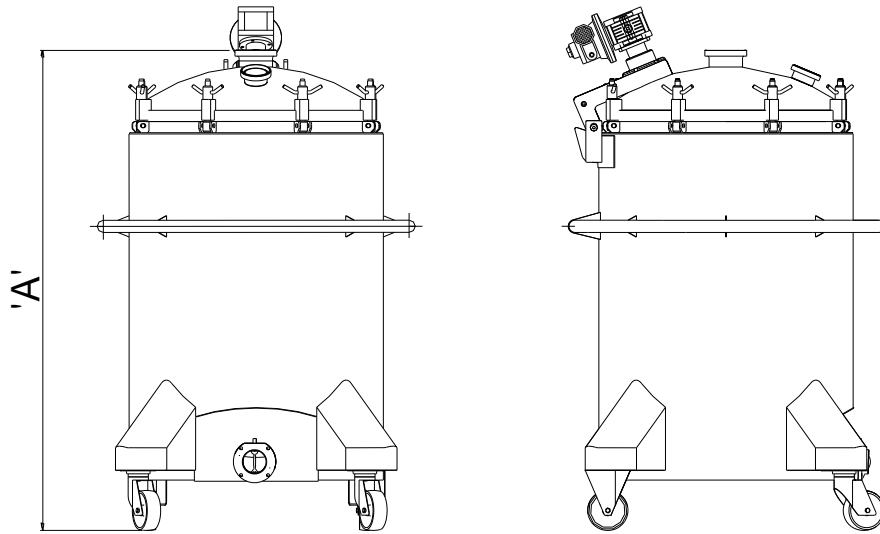

<b>Capacity</b>	<b>80</b>	<b>100</b>	<b>125</b>
<b>Dim 'A'</b>	57"	58"	75"



**D C Norris North America LLC**

2375 Traversefield Drive  
 Traverse City  
 MICHIGAN  
 49686  
 USA

**t:** (+1 ) 231. 935. 1519

**e:** mail@dcnorrisna.com

**w:** www.dcnorrisna.com



**DC NORRIS**  
 NORTH AMERICA